



KEPNER

PRODUCTS COMPANY

Kep-O-seal® Ball Check Valves

The 400 series Kep-O-seal® Ball Check Valves have large flow paths, incorporate the Zero Leakage *Flexible Seal Seat™* and have a conical tension spring. Vibration and chatter have been eliminated and the ball checks accept most contamination and high viscosity fluids. It has been designed for general purpose oils and lubricants, hydraulic oil, air and water. Rated at 3,000 psi operating pressure, 4,500 psi proof pressure and 1 to 2 psi standard crack pressure, the valve is available in brass and stainless steel with Buna-N, Teflon® or Viton® O-rings.

Viscous Liquid Filling Application

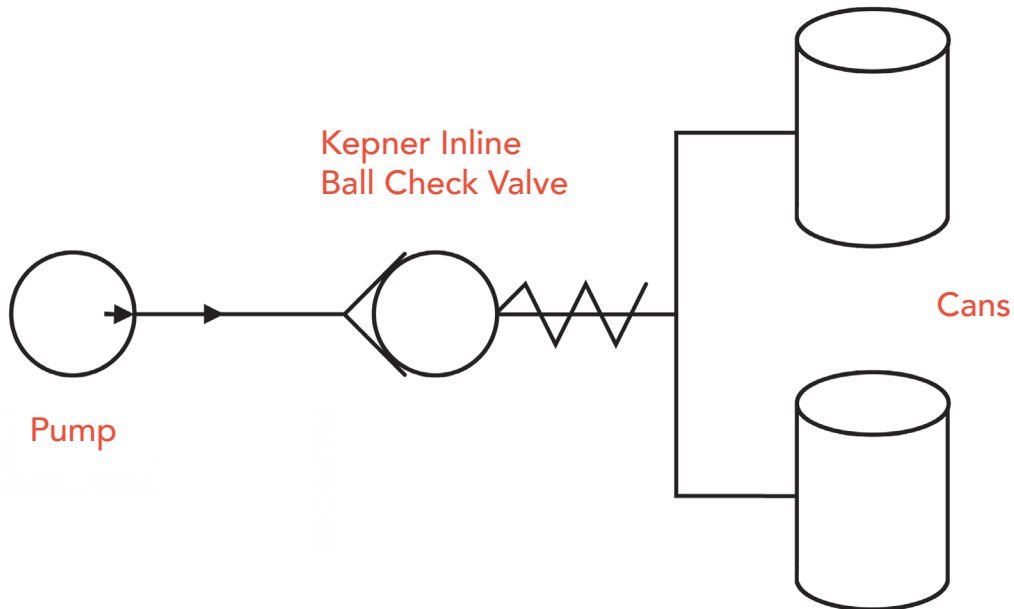

Consult Factory or Distributor for more help. Customer/user is solely responsible to select products suitable for their specific application requirements and to ensure proper installation, operation and maintenance of these products. Improper selection or use of products can cause personal injury or property damage. All sales are subject to Kepner Products Company Standard Terms and Conditions of Sale. Designs are subject to change without notice.